

SECTION B-B

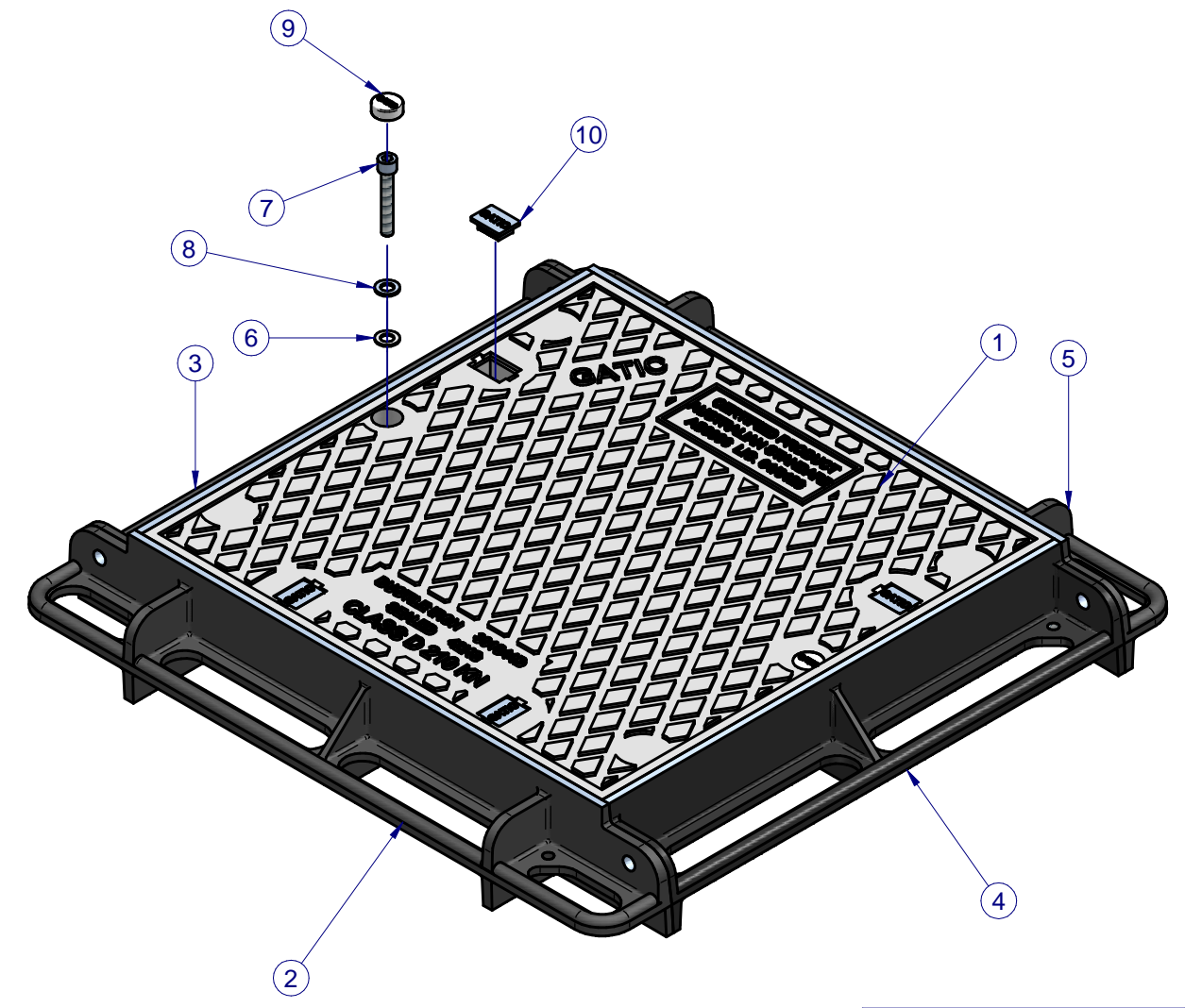

**NOTE:**  
8 only of M10x50 Hex head bolts required for assembly C/W washers and nuts.

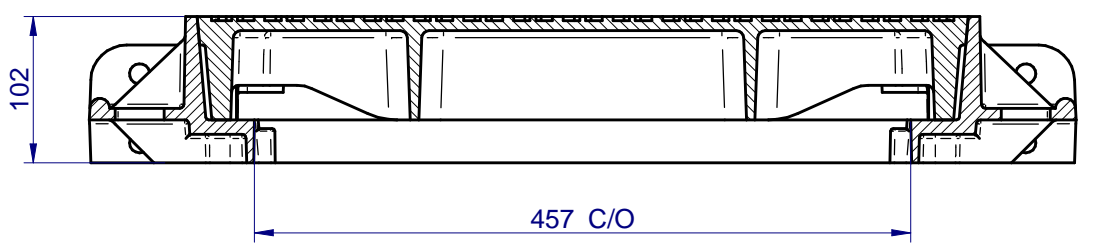

SECTION A-A

Item No.	Dwg.	Rev.	Title	Material	Qty.	Mass
1	2186	C	457x457 C/O Solid Top Cover Class D	Ductile Iron 500-7	1	41.3 kg
2	4000	B	457mm Draw Cut Bar Class D	Ductile Iron 500-7	1	9.2 kg
3	4001	C	457mm LH Side Bar Class D	Ductile Iron 500-7	1	7.7 kg
4	4002	C	457mm RH Side Bar Class D	Ductile Iron 500-7	1	7.7 kg
5	4003	B	457mm Under Cut Bar Class D	Ductile Iron 500-7	1	7.7 kg
6	2856	A	M10 Washer	Nylon, general purpose	2	0.0 kg
7	2857	A	M10x65 Socket Head Cap Bolt	Stainless Steel, 304	2	0.1 kg
8	2855	A	M10 Washer	Stainless Steel, 304	2	0.0 kg
9	2854	C	Plastic Plug Ø26 mm	UV Stabilized Nylon	2	0.0 kg
10	1681	A	Plastic Keyhole Plug	UV Stabilized Nylon	4	0.0 kg

Copyright : Gatic Pty Ltd - 2015

REVISION	No	DATE	DESCRIPTION	BY	S.S.	CKD.
A	30-01-15	INITIAL RELEASE.		F.M.	S.S.	

**UNLESS OTHERWISE STATED**  
 ALL MEASURES IN MILLIMETERS.  
 GENERAL CAST TOLERANCES: CT9 to ISO 8062.  
 CASTING RADII: 3 mm  
 DRAFT TAPERS: 2°

LINEAR MACHINING TOLERANCE:  
 X. ±0.25 mm  
 X.X ±0.10 mm

ANGULAR MACHINING TOLERANCE:  
 X. ±0.5°  
 X.X ±0.1°

NOM = Nominal; O/A = Overall; TYP = Typical; C/O = Clear Opening

**FINISH:** ALL CAST SURFACES TO BE PAINTED AS SPECIFIED. FABRICATED COMPONENTS TO BE HOT DIP GALVANISED TO AS/NZS 4680. LIGHT FILM OF GATIC SEALING GREASE TO BE APPLIED ON ALL MACHINED SURFACES.

**GATIC** PTY LTD  
 9-15 Radford Road, PO Box 312, Reservoir VIC. 3073  
 Ph- 03 9316 2666 Fax- 03 9315 0099 www.gatic.com.au

THIRD ANGLE PROJECTION

DESIGNED: --	DATE: --	CODE: GM301S44D	TITLE: 457X457 SOLID TOP COVER & FRAME CLASS D - ASSEMBLY
DRAWN: F.M.	30-01-15	SCALE: N.T.S.	MATERIAL: --
CHECKED: S.S.	30-01-15	FORMAT: A3	DRG. No: 5069
APPROVED: H.B.	30-01-15	SHEET: 1 of 1	MASS: 73.7 kg